

A COMPARATIVE STUDY FOR STRENGTH CLASSIFICATION

DAYANIM SINIFLANDIRMASI İÇİN KARŞILAŞTIRMALI BİR ÇALIŞMA

Taha Abdallah *
Hany Helal *

Keywords : Compressive Strength, Point Load Strength Index, Schmidt
Hammer Rebound Number, Tensile Strength

ÖZET

Dayanım sınıflandırması için sağlanan bir sistemin önemi deney yöntemlerinin niteliği, gerekli temsili numune sayısı ve deney ekipmanlarıyla vurgulanmaktadır. Bu çalışmada üç tip Mısır kayacı : Değişik numune boyutlarındaki Kireçtaşı, Kumtaşı ve Granit, tek eksenli basma, nokta-yükleme ve Schmidt çekici teknikleri kullanılarak tek eksenli dayanımlarının belirlenmesi için karşılaştırmalı bir çalışmada kullanılmıştır. Deney sonuçları istatistiksel olarak analiz edilmiş ve gözeneklilik, yoğunluk ve iletme hızı gibi bazı fiziksel özellikleriyle korelasyonu yapılmıştır.

ABSTRACT

The importance of providing a system for strength classification is emphasized by the diversity of testing methods, number of representative samples needed, and testing equipment required. In the present work three Egyptian types of rocks: Limestone, Sandstone and Granite with different specimen sizes are used to carry out a comparative study concerning the determination of the compressive strength using uniaxial compression, point-load, and Schmidt hammer techniques. Testing results are statistically analyzed and correlated with some physical properties like porosity, density and sound velocity.

* Associate Professor, Mining Department, Faculty of Engineering, Cairo University

1-INTRODUCTION

Rock blasting plays an important role in determining the efficiency and economics of the whole surface mining operations (Harries et al ,1975). Improving the blasting efficiency means lowering the rejected percent of the product. This portion is defined by the size of fines and/or oversize according to the type of the product and end-user requirements.

Blasting efficiency can be evaluated by different design methods. The definition of efficient blasting is based on the idea that increased energy expenditure is required in blasting to obtain better fragmentation, but better blasting lowers the cost of loading, hauling, crushing and protecting newly opened slope faces thus assisting the next drilling and blasting operation. After Sunu et al (1988), the design methods which are available for assessing the performance of blasting and fragmentation in a rock mass can be categorized as follows: -

- * Physical and observational methods
- * Empirical methods
- * Analytical methods.

Physical methods or reduced scale blasting in the laboratory or in the field provide experience in fragmentation assessment and results that could be used to optimize the expensive full-scale field tests. However, at reduced scale, rock structures such as bedding and jointing are exaggerated and can have an unrealistic effect ,(Sunu et al, 1988 and Stagg,1987). Blasting is still considered to be an art. Selection of optimum burden, or the powder factor, is still a matter of experience. Very often the design engineer or "blaster in-charge" prefers to use simple empirical formulae for their blast designs (Paul & Gershon,1989) Analytical methods include, finite element, finite difference, boundary element and distinct element codes, are used to simulate blasting and the effect of different rock parameters on fragmentation. Many investigations were

limited to two dimensional analysis, where some difficulties were observed in simulating the effect of structural geological discontinuities on blasting which occur in a rock mass three dimensionally.

Consequently, it must be borne in mind that the finite element method should be used together with empirical and field studies to compare and improve the design requirements, (Sunu et al, 1988).

Design of blasting rounds in surface mines depends upon the physical and structural properties of the material, the type of explosive to be used, and the distance of throw (i.e., in case of casting of over burden). Due to the variations in these properties and different mine conditions, there does not exist a single theory or set of formulae which can be used efficiently for blast design in surface mine operations, (Paul&Gershon,1989).

Abdallah et al (1992) had tried previously to present a computational approach with the objective to recommend an efficient blast pattern design capable to produce a broken ore having a degree of fragmentation suitable for the processing plant. The proposed mathematical model has failed because it is based on hypothetical assumptions and does not take into consideration the real characteristics of the site.

2-ADOPTED METHODOLOGY

Since, the blasting, results are always site specific, the borehole pattern and loading practices must vary with the rock formations encountered. Trial blasts and computer simulations are the best means of determining optimum explosive loads and blast patterns for each set of conditions, (Singh, 1988).

The methodology adopted stated that for each site;-

2.1. A complete data base having all informations about field blasting operation. This data base must include geotechnical rock characteristics, explosive characteristics, blast pattern design and finally the size distribution of fragment.

2.2. The correlation matrix is consulted first to test the correlation between the different variables.

2.3. A regression analysis will help then to formulate the mathematical relations between these distinguished variables.

2.4. A model is subsequently constructed using these mathematical relations and tested using the informations acquired in the data base.

2.5. If model results are acceptable (according to a certain confidence limit) the model is said to be reliable otherwise, further data are needed to improve the regression analysis and consequently raise the degree of reliability of the model.

2.6. If any other new parameters are introduced (new site , new face) all the procedures have to be reevaluated to take into account these new conditions otherwise, the model will fail.

3-CASE STUDY

A limestone quarry will be used as an example to illustrate the proposed modelling methodology.

Among the parameters influencing the blasting efficiency, the following ones are of valuable interest, these are rock tensile strength, powder factor, type and mixture of explosive, and the geometric pattern,(Abdallah et al, 1992).

The methodology adopted is then demonstrated by the following steps :

3.1 Table (1) gives the correlation matrices of the variables. From which it is clear that certain relationships between the % age of fines, the % age of oversize and the different influencing parameters exist

Table (1). The Correlation Matrix

Parameters	%Fines	%Oversize
Tensile Strength (kg/cm ²)	-0.98884	0.91024
Powder Factor (kg/m ³)	0.98312	-0.89565
Gelaine %	0.95834	0.01777
Burden (m)	-0.88604	0.82956
Spacing (m)	-0.97812	0.85653

Table (2). The Regression Analysis

Mathematical Relation	Correlation Coefficient	Standard Error of Estimation
$1/TS = 2.89915E - 3 + 2.25562E - 3 * X1$	0.977459	0.001
$1/TS = 0.0330335 - 9.49354E - 4 * X2$	-0.869516	0.002
$PF = 0.205722 + 0.01238 * X1 - 0.007487 * X2$	0.995966	0.007
$G = .281719 + 2.46855 * X1$	0.998625	2.506
$B = 3.745348 - 0.069943 * X1 + 0.081592 * X2$	0.99505	0.107
$S = 4.385096 - 0.102961 * X1 + 0.073633 * X2$	0.988464	0.185

Where X1 = % Fines
 TS = Tensile Strength (Kg/cm²)
 PF = Powder Factor (Kg/m³)
 X2 = % Oversize
 G = Gelaine %
 B = Burden (m)
 S = Spacing (m)

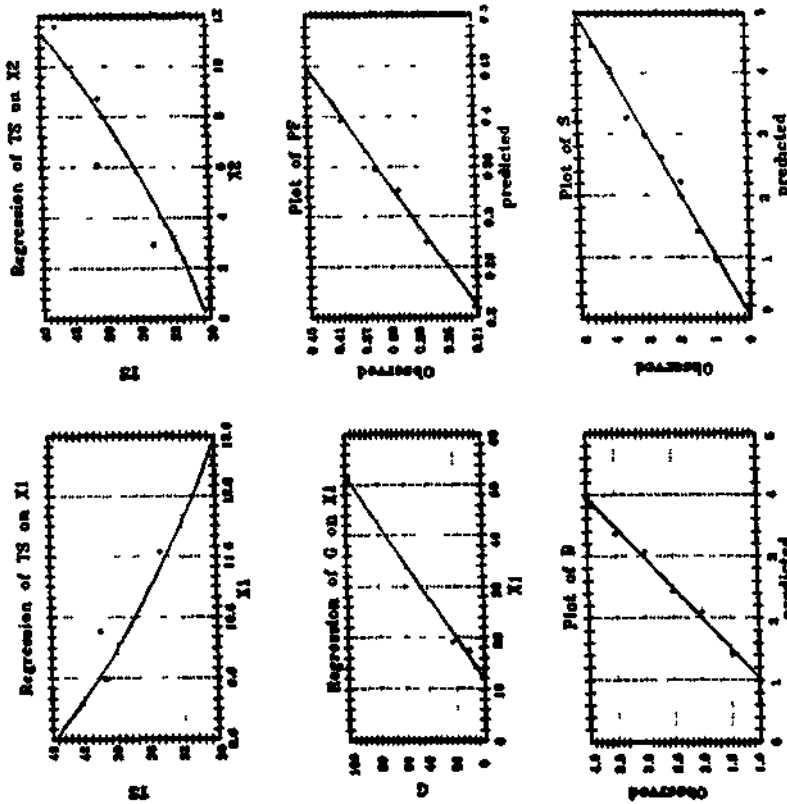

Figure(1). Statistical Analysis

3.2 Regression analysis is then followed looking forward the different possible relations which could give the best correlation coefficient meanwhile the standard error of estimation is kept to the minimum possible attained. Results of this analysis are shown in table (2) and figure (1).

3.3 As the mathematical relation between different variables are found according to field experiments, the model is then constructed to fulfil the requirement of end-user. Figure (2) illustrates the algorithm of this blast model.

3.4 This algorithm is based upon the determination of the tensile strength (as the only available geotechnical parameter in our case study) and accordingly it calculates the corresponding percentage of fines and oversize expected. The model then gives the powder factor, gelatine %age in the mixture (anfo+gelatine), the burden and finally the spacing. If the user wishes to have another % age of fines or oversize to fulfil production requirements he has to define one of those parameters and the model calculates the corresponding other value and finally proceeds to the calculation of other parameters.

4-RESULTS AND DISCUSSION

The model was tested using the available data of field experiments on the limestone quarry . During the formulation of this model ;two main problems were raised:

4.1.TheDataBase:

The only available information about rock geotechnical characterization is the rock tensile strength. The data given for the chosen limestone quarry, was not sufficient to carry out a regression analysis with other geotechnical parameters. The determination of site geotechnical map is a must. Naidu & Singhal(1987), stated that for a given amount of heave energy and a certain blast geometry, susceptibility of a rock mass to blast casting increase with a decrease in rock density and with an increase in Young's modulus (E). The nature, extent and direction of joints and bedding planes will contribute to the

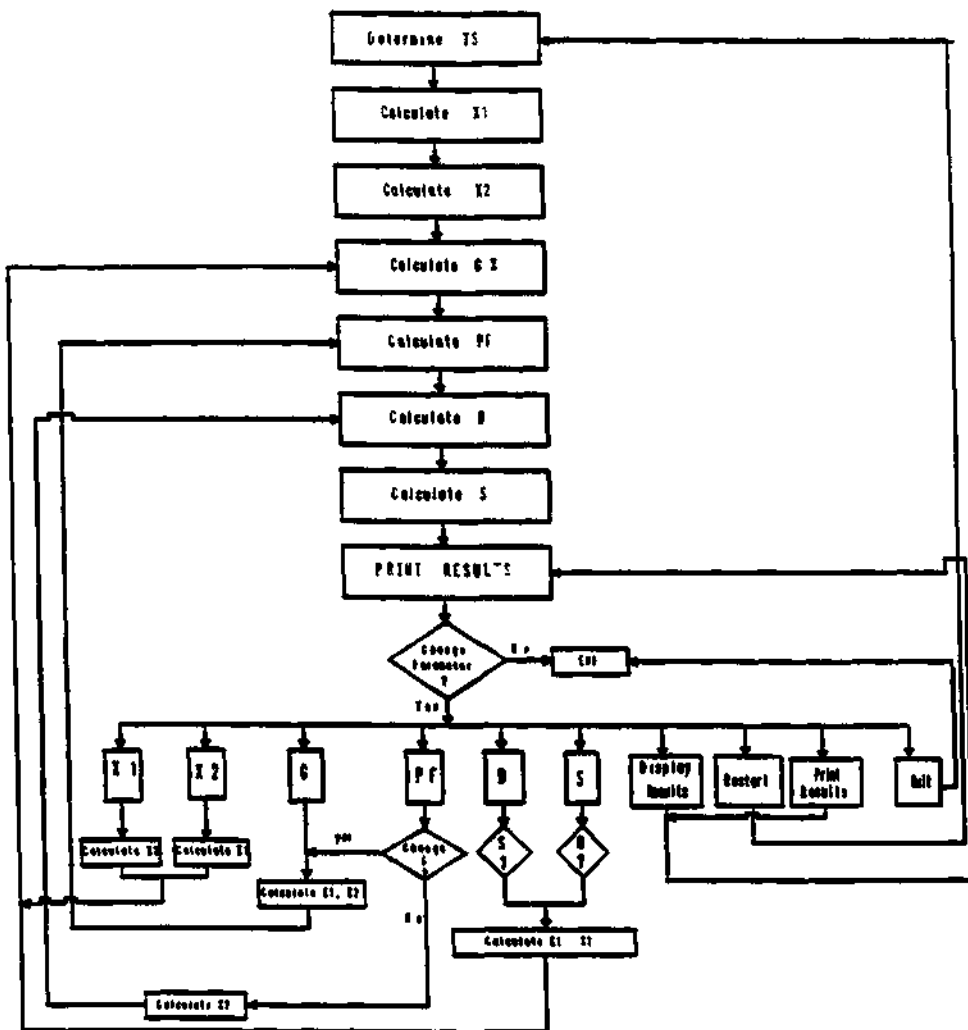

Figure (2). The Algorithm Of Model Presented

effectiveness of blasting. When major discontinuities are at right angles to the free face, explosion gasses have greater opportunity to escape prematurely to the atmosphere. Where the major discontinuities are parallel to the free face, there is more interaction between adjacent blast holes.

The effect is clear in the presented model where the tensile strength is used to calculate the expected % age of fines and % age of oversize. Using these two expected values the other parameters(gelatine %, powder factor, burden and spacing)are subsequently calculated. Hence, the necessity of finding out another mathematical expression relating different geotechnical parameters with % fines and % oversize.

4.2.The Limiting Conditions :

This factor manifested by some negative signes resulted from mathematical relations. These unrealistic results focus the light on the limiting conditions of each mathematical relation. These limiting conditions are site specific as being results of regression analysis on field experiments data . Hence, the limiting values of each parameter (lower and upper limits) must be claimed, during the execution of the model and before any declaration of each value as shown in figure (3).It is clear from the gelatine percent relation (G) that more experiments are needed to lower the standard error of estimation which seems to be slightly high . Also, this relation imposed small margins on the selected parameters. This is demonstrated by table (3).It was assumed that the relation $G = f(XI)$ is not defined for negative values of G (i.e $0 \leq G \leq 100$). This condition gives a wider range for the other parameters as shown in table (3). On the other hand, if this last assumption was not respected and the mathematical relation of gelatine percent is tightly respected ,a very small interval is obligatory used (i.e. $0 \leq G \leq 4.8$). This also emphasizes that more field experiments have to be carried out.

Figure (3) shows the print-out of programme execution. The model is tested using the only available data of the considered limestone quarries. The limiting conditions

Table(3).Limiting Conditions

0.0 <• G <" 100	0.0 <- G <* 4.8
30.3 <- TS <- 344.9	30.3 <- TS <- 34.9
0.0 <- XI <- 1336	11.41 <- XI <- 1336
0.0 <- X2 <- 31.74	0.0 <- X2 <- 4.63
0.13 <- PF <- 037	031<- PF <- 0.37
2.81 <- B <- 6.34	2.81 <- B <- 333
3.0 <- S <- 6.72	3.0 <- S <- 3.53_

Rock Tensile Strength (Kg/cm²) = 35.0

% Fines = 13.44

% Oversize = 2.95

Gelatine % < 5.0

Powder Factor (Kg/cm³) < 0.35

Burden (m) = 3.0

Spacing (m) = 3.2

TOUCH ANY KEY TO CONTINUE

1%Fines 2%Overs 3Geltn% 4PowdrF 5Burden 6Spacng 7Disply 8Restrt 9Print 10Quit

Figure(3). Print - Out Of Program Execution

imposed by the mathematical relations have to include a wider range of parameters to give the model more flexibility . This could be done by carrying out more experiments in the same site and in different sites in the quarry and if possible in other limestone quarries. Whenever possible that further data are available , the model outputs are becoming more reliable. Also this will help in arriving to more general mathematical model applicable to any limestone quarry using the same techniques.

However, two factors were not included in the presented model ; energy factor and blast delay time. Energy factors were not included. According to Naidu & Singhal(1987), powder factors expressed in Kg/m^3 are not a useful design criterion in blasting. The reason for this, is that the ejection velocity and lateral displacement of the burden rock are related to the weight rather than the volume of the rock. Because the energy generated per unit weight of charge varies with the chemical composition of the explosive, one should use energy factors rather than powder factor as a blast design criterion. It is the amount of explosives' energy (not the weight of explosive) which controls the displacement of each ton of rock.

The influence of blast delay time has to be considered. The effect of delay time on the interaction between shotholes is going to affect the fragmentation process. An acceptable range of delay time provides the blast design tools useful for variety of purposes, including optimum muck pile displacement and vibration control (Stagg,1987).

5-CONCLUSION AND RECOMMENDATIONS

Analysis of present results confirm the fact that design of blasting rounds in surface mines depends upon the physical , mechanical and structural properties of the material, and explosive's characteristics. Due to the variations in these properties and those of job and management, the mining engineer prefers to use simple empirical formulae for the design of blast pattern. Actually, there does not exist a single theory or

set of formulae which can be used efficiently for blast design in surface mine operations. Therefore, the methodology presented based on trial field experiments and simulation is the best approach to give more realistic solutions. The flexibility of this model depends mainly on the data gathered from field experiments which could impose either flexible or rigid limiting conditions on the various parameters.

It is recommended to :

- Create a data base containing all the available informations about mining job and management conditions, experiments, testingetc.
- Mine geotechnical map is a must . The effect of discontinuity on blasting efficiency is obvious. Also, mechanical and physical properties of material have great influence on fragmentation and must be included in the model.
- Energy factors and blast delay time must be considered .
- Extend the experiments all over different sites and quarries /mines of the same type of the material extracted to arrive at general mathematical relationships .

^ACKNOWLEDGEMENT

The author would like to thank Prof. H.F.Imam for his valuable guidance during the realisation of this work .

7-REFERENCES

T. ABDALLAH, Z. AGAMY AND S EL-ADAWY, 1992, " Contribution To Blasting Engineering As Practiced In Agran El-Foul Limestone Quarry ", Jour, of Eng. and Applied Science, Fac. of Eng., Cairo Univ., Vol 39, No. 3, pp.603-617.

HARRIES, D. AND MERCER, J.K., 1975; " The Science Of Blasting And Its Use To Maximize Costs ", Proc. of the Australian Inst. Min. Metall. Conf. Adelaide, Part B , pp. 387-399.

H.G. NAIDU AND R.K.SINGHAL, 1987; " The Potential For Cast Blasting In Canadian Surface Mines ", Int. Jour, of Surface Mining, Vol. 1, pp. 243-249, Balkema

JYOTI PAUL AND MARK GERSHON, 1989; " Fragmentation Systems Design In Surface Mines : An Expert System ^M, Int. Jour of Surface Mining, Vol. 3, pp. 127-131, Balkema.

SP. SINGH, 1988; " Blast Design In Monumental Stone Quarries ", Int. Jour, of Surface Mining, Vol. 2, pp. 33-36, Balkema.

MARK S. STAGG, 1987; " Influence Of Blast Delay Time On Rock Fragmentation : One-Tenth Scale Tests ", Int. Jour, of Surface Mining, Vol. 1, pp. 215-222, Balkema.

**MUSTAFA Z. SUNU, SIMON M. REED AND RAGHU N. SINGH, 1988;
" Evaluating The Effect Of Rock Parameters On Surface Mine Blasting By Finite Element Analysis ", IntJour. of Surface Mining, Vol. 2, pp. 209-215.**