

## New Anchorage Capacity Testing System and Pull-Out Applications in Yeniçeltek Coal Mine

E. Taşel & T.T. Ozan

*Atlas Copco Makinaları İmalat A.Ş., Istanbul, Turkey*

E. Ünal

*Department of Mining Engineering, Middle East Technical University, Ankara, Turkey*

MBildik

*Yeniçeltek Kömür ve Madencilik A.Ş., Merzifon, Amasya, Turkey*

**ABSTRACT:** A unique 45-ton-capacity, pull-out testing system was developed in METU Mining Engineering department. This system is capable of testing different types of rock bolts and cable bolts. In-situ pull-out tests were carried out in Yeniçeltek Coal Mine using Standard Swellex bolts. A 20-m section of this roadway was successfully supported by these bolts. It was shown that the cost of roadway support can be reduced by about 50%.

### 1 INTRODUCTION

In recent years, the range of applications of rock bolts has widened due to advances in rock mechanics, developments in rock reinforcement concepts, and better understanding of rock mass and rock bolt interaction mechanisms. Consequently, the use of rock reinforcement systems in underground excavations has increased as an alternative to more traditional forms of support.

Several types of rock bolt testing systems, such as destructive, non-destructive and overcoring techniques, have been developed for understanding the working principle of a rock bolt in different rock masses. The pull-out test is a typical destructive test performed for determining the anchorage capacity of rock bolts. During pull-out tests, bolt displacement is measured as a function of the applied bolt load. The anchorage capacity is one of the input parameters used in rock reinforcement design. It is also used for controlling the quality of bolt material and installation method.

Currently, it is not possible to test all rock bolt types utilising a single pull-out testing system. Usually a special type of pull-out test device has to be prepared for each kind of rock bolt since the head and manufacturing principles of each type of rock bolt are different.

In this paper, a unique 45-ton-capacity, pull-out testing system that can be used for all rock bolt types is introduced. The pull-out tests carried out in Yeniçeltek Coal Mine are also presented.

### 2 NEW ANCHORAGE CAPACITY TESTING SYSTEM

This system was developed in METU Mining Engineering department.

#### 2.1 General layout of the testing system

In general, the anchorage capacity testing system consists of three main parts, namely, mechanical, hydraulic and electronic.

##### 2.1.1 Mechanical part

The mechanical part of the system consists of four main components, namely the (i) pull collar, (ii) connector, (iii) pull bar, and (iv) reaction frame. The pull collar, connector and pull bar are installed onto each other such that they can pull the rock bolt out of the hole in the direction of the bolt's centerline. The reaction frame was designed to fit the dimensions of the pulling unit and hollow ram. It has four adjustable legs. These legs can be adjusted on a rough surface to keep the pulling direction on the longitudinal axis of the rock bolt. An engineering drawing and a photograph of the mechanical parts installed on each other are shown in Figures 1 and 2 respectively.

##### 2.1.2 Hydraulic Part

The hydraulic part of the system comprises: (i) hydraulic hand pump and manometer, (ii) hydraulic hose, and (iii) hydraulic hollow ram having a capacity of 60 tons.

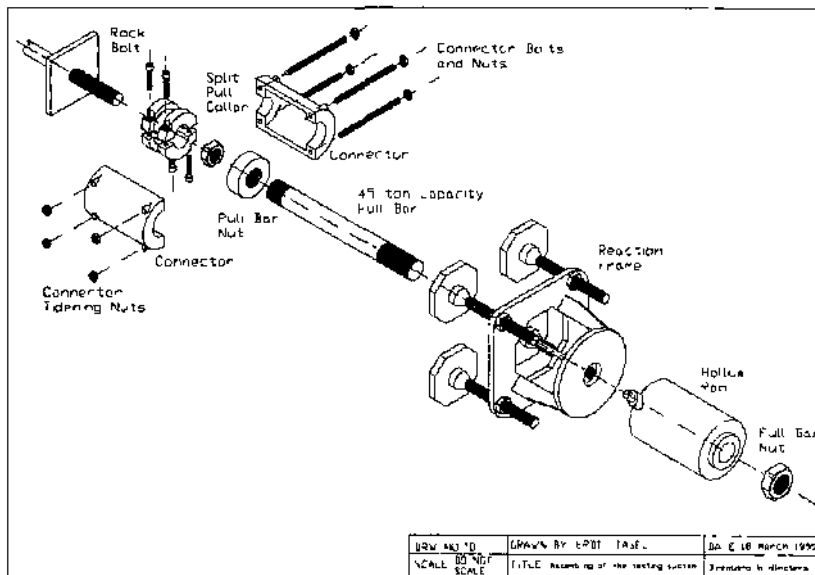

Figure 1. Assembly of the mechanical part of the pull-out test system with hollow ram



Figure 2. Mechanical part of the pull-out test system

A simple sketch of the hydraulic part of the system is shown in Figure 3. The hollow ram and the hydraulic pump can also be seen in Figures 2 and 5.

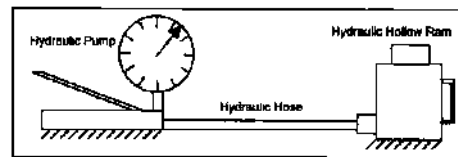

Figure 3 Hydraulic part of the test system.

### 2.1.3 Electronic part

A data acquisition system is essential to handle the massive amount of data obtained during testing and to be able to plot the load-displacement curves.

This system is installed onto the connector with the help of gauge connection bars. The system is capable of taking either electronic or mechanical readings. This is essential because of the limitations in use of A.C. in some underground coal mines. In the METU testing system, the data acquisition part consists of the following components: (i) pressure transducer, (ii) electronic or electromechanical dial gauges or LVDTs, (iii) signal conditioner (input voltage source, filter), (iv) strain indicator (amplifier), and (v) recorder (personal computer with A/D converter card).

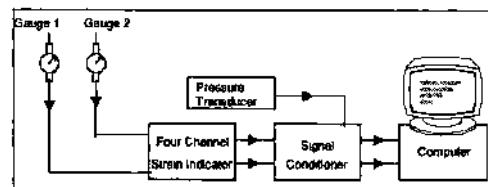

Figure 4 Schematic illustration of the electronic part of the test system.

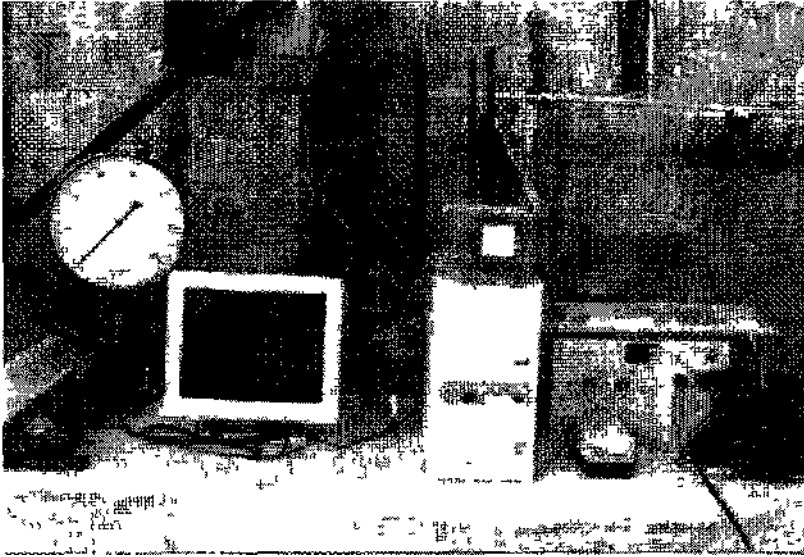

Figure 5. A view of the electronic data acquisition system

### 3 PERFORMANCE TESTING

During the development of the anchorage testing system, two types of tests were carried out. The "stability tests" provided information about the stability of the mechanical, hydraulic and electronic components. The capability tests provided information about the suitability of the system for testing different types of rock bolts in various rock-mass conditions. The stability tests were carried out in the METU rock mechanics laboratory and the whole system was checked with a 200-ton-capacity hydraulic testing machine. During these tests, the behaviour of each component of the system was monitored under specific loads. The "capability tests", on the other hand, were performed on different types of rock bolt installed in large-diameter confined hollow specimens made of different qualities of concrete. The confinement was provided by means of steel cells. During these experiments, the testing difficulties were identified.

The anchorage testing system and the confined and bolted specimens are shown in Figure 6.

## 4 PULL-OUT TESTS IN YENIÇELTEK COAL MINE

### 4.1 *Yeniçeltek underground coal mine*

Yeniçeltek lignite mine is near the Merzifon-Samsun highway, located about 15 km east of Merzifon, 35 km northwest of Amasya and 90 km south of Samsun

In general, the thickness of the coal seam ranges from 8 to 12 meters. However, only the upper portion of this seam is mined due to the higher calorific value, determined as 4100 kcal/kg (Günyagüler and Ünal, 1998).

In Yeniçeltek Lignite Mine, the retreat longwall mining method is used. The length of the longwall faces is about 80 meters. The faces are supported by two or sometimes three rows of 40-ton-capacity individual hydraulic props, installed under steel caps 1.25 meters long. The excavated coal is transported by double-chain conveyors in the face, by band conveyors in the gate roads, and by loco-trains in the mine roadways. Finally, after travelling a long distance, the coal is transported to the surface with the help of a skip.

### 4.2 *Test site*

The anchorage capacity tests were carried out in a new haulage way known as "256/210 inclined". This incline is at a distance of about 1 km from the skip bottom, and will connect the +256 level to the +210 level. It will be used to transport the coal that will be produced from new panels of the 302 region. A schematic illustration of the test location is shown in Figure 7.

### 4.3 *Test equipment*

During underground tests, only the mechanical-hydraulic system was used. This system consists of the following parts:

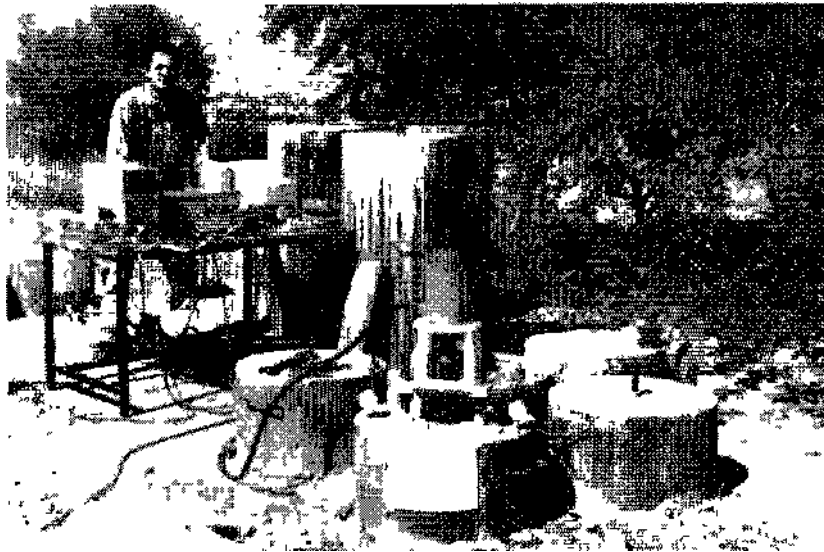

Figure 6. Pull-out tests were simulated on mechanically anchored rock bolts and swellex bolts.

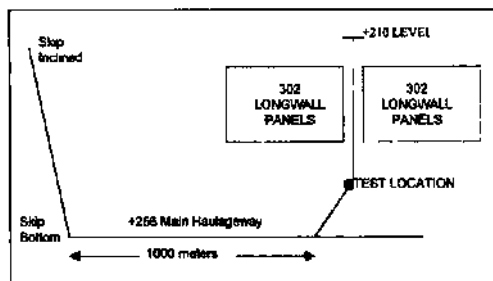

Figure 7. Schematic illustration of the test location at Yeniçelték coal mine

1. Mechanical Part.
  - a) 26-mm split pull collar.
  - b) Connector.
  - c) 25-ton-capacity pull bar.
  - d) Reaction frame.
  - e) Dial gauge connection bars.
  - f) Extensometer.
2. Hydraulic Part.
  - a) 60-ton-capacity hollow ram.
  - b) Hydraulic hose.
  - c) Hydraulic hand pump.
  - d) Manometer.

Anchorage capacity tests were carried out on 2.4-meter-long Standard Swellex bolts. During the first series of tests, a hole about 2.4 m long was drilled in the roof of the haulage way. After the drilling operation, the 26-mm split pull collar was connected to a bolt head and a Swellex bolt was inserted into the

drillhole and inflated at a pressure of 280 bar. Following this step, the mechanical components and the 60-ton-capacity hollow ram, hydraulic hand pump and a calibrated manometer were installed. Finally, a telescopic extensometer was placed under the pull-out test system to measure the displacement data.

During the second series of tests, the same equipment was used. However, instead of the extensometer, two mechanical dial gauges were connected to the connector body with the help of the dial gauge connection bars. Thus, displacement measurements were taken between the roof and the bolt. This system can be visualised by turning the pull-out system, shown in Figure 2, upside down. In both tests, safety changes were made to prevent a sudden drop of the system from the roof.

#### 4.4 Test results

##### 4.4.1 First series

A general view of the testing system and the test location is shown in Figure 8. During testing, an initial arbitrary load of 5 kN was applied to take up the slack in the equipment. Following this step, the load was increased in steps of 5kN. The resolution of the displacement dial gauge was 0.01mm. A typical load-displacement plot obtained from the first series of measurements is shown in Figure 9. As a result of these tests, the anchorage capacity of the Standard Swellex bolts was found to be 90.5kN.

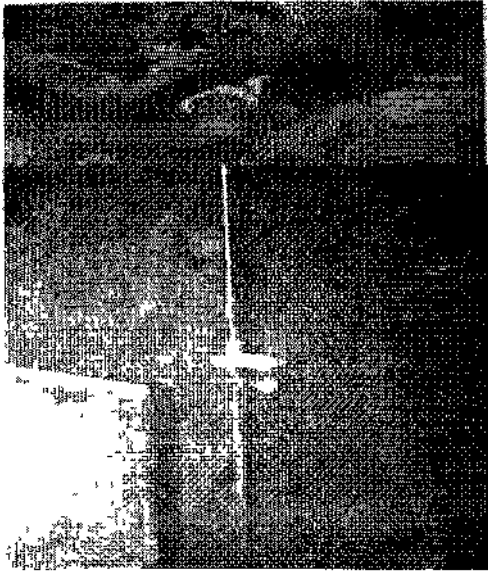

Figure 8. Pull-out test equipment and the extensometer used during the first series of tests.

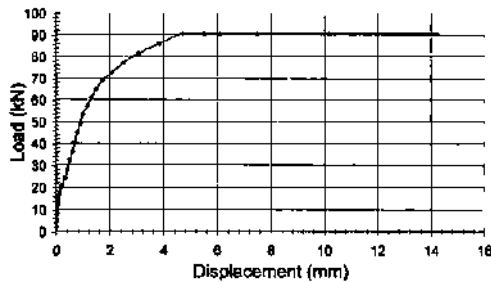

Figure 9 A typical load-displacement plot obtained during the first series of tests earned out in Yenicektek underground mine.

#### 4.4.2 Second series

During this series, instead of a telescopic extensometer, two mechanical dial gauges were used due to the low height of the roadway. A typical result obtained from these series is shown in Figure 10. As a result of these tests, the average anchorage capacity of the Standard Swellex bolts was found to be 10kN.

## 5 ROCK REINFORCEMENT DESIGN

During the anchorage capacity tests, the test site was supported by traditional steel arches. Based on the results of these tests, the rock-mass classification studies carried out at the test site, and Ünal's rock reinforcement design codes (1983, 1990, 1999), a 20-m section of the roadway was supported with

Standard Swellex bolts. Consequently, it was possible to compare the performances of the roadway supported by both steel arches and Swellex bolts.

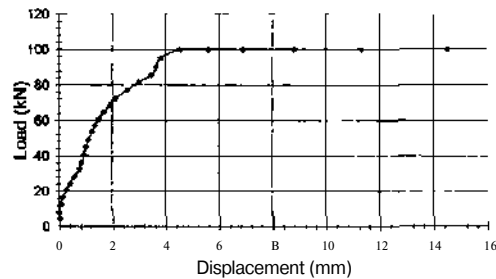

Figure 10. A typical load-displacement plot obtained during the second series of tests earned out in Yenicektek underground mine

## 6 CONCLUSIONS

The main findings of this study are the following:

1. The METU pull-out testing system is capable of testing different types of rock bolt, such as mechanically anchored bolts, grouted rock bolts, frictional rock bolts (split-set and Swellex) and most cable bolts having capacities of less than 45 tons.
2. By evaluating the results of the anchorage capacity tests, the modified rock-mass rating (mRMR) values and the design method suggested by Ünal, a 20-m section of this roadway was successfully supported by Swellex bolts. This roadway has been stable ever since.
3. As a result of this application, it was shown that the cost of roadway support can be reduced about 50%.
4. Due to the simple installation procedure of the Swellex bolts, the time required to support the roadway can also be reduced considerably.

## REFERENCES

- Gıyaguler, T. & Ünal, E. 1998. Yenicektek ve Sorgun Linyit İşletmelerinin rezerv durumlarının belirlenmesi, ekonomik olarak işletilmesi ve yem teknoloji olanaklarının araştırılması projesi. *Proje kod no ODTÜ Ağustos, 98-03-05-01-05. Ankara. Orta Doğu Teknik Üniversitesi Maden Mühendisliği Bölümü. Aralık 1998*
- Taşel, E., 1999. *Development of a new pull-out testing system for rock bolts* M Sc. Thesis, Department of Mining Engineering, Middle East Technical University, Ankara, Turkey.
- Ünal, E., 1983. *Design Guidelines and Roof Control Standards for Coal Mine Roofs*. Ph D Thesis, Pennsylvania State University, University Park, USA.
- Ünal, E., 1999. Special communication
- Ünal, E. and Ergür, K. M., 1990. PC based modeling of rock reinforcement requirements in mine roadways. *Proc of 31<sup>st</sup> US Symp Rock Mechanics Contributions and Challenges*, 761-768.

